

# ROUGH TERRAIN CRANE

**TR-100ML**  
**TR-100M**

(6-section Boom, 1-staged Jib, X-type Outrigger)

*JAPANESE SPECIFICATIONS*

**TR**

CARRIER MODEL	OUTLINE	SPEC. NO.
TR-100ML	Max. total rated load 10 ton	TR-100M-1-00105
TR-100M	Max. total rated load 4.9 ton	TR-100M-1-00107

Control No. JA-02

# TR-100ML, TR-100M

## CRANE SPECIFICATIONS

### CRANE CAPACITY

5.2m Boom	10,000kg	at 2.5m (8part-line) ...TR-100ML
	4,900kg	at 3.9m (4part-line) ...TR-100M
8.8m Boom	4,900kg	at 4.0m (4part-line)
12.4m Boom	4,900kg	at 4.0m (4part-line)
16.0m Boom	4,000kg	at 4.5m (4part-line)
19.6m Boom	3,500kg	at 4.5m (4part-line)
23.2m Boom	2,000kg	at 6.0m (4part-line)
2.8m Jib	1,400kg	at 75° (1part-line)
Single top	1,400kg	(1part-line)

### MAX. LIFTING HEIGHT

Boom	23.9m *
Jib	26.7m

### MAX. WORKING RADIUS

Boom	21.9m
Jib	22.8m

### BOOM LENGTH

5.2m - 23.2m

### BOOM EXTENSION

18.0m

### BOOM EXTENSION SPEED

18.0m/54s

### JIB LENGTH

2.8m

### MAIN WINCH SINGLE LINE WINDING SPEED

114m/min (5th layer)

### MAIN WINCH HOOK SPEED

28.5m/min (4 part-line)

### AUXILIARY WINCH SINGLE LINE WINDING SPEED

98m/min (3rd layer)

### AUXILIARY WINCH HOOK SPEED

98m/min (1 part-line)

### BOOM ELEVATION ANGLE

-2° - 82°

### BOOM ELEVATION SPEED

-2° - 82°/30s

### SWING ANGLE

360° continue

### SWING SPEED

2.8min<sup>-1</sup>(rpm)

### WIRE ROPE

Main Winch:	10mm x 127m (Diameter x Length)
	Spin-resistant wire rope
Auxiliary Winch:	10mm x 60m (Diameter x Length)
	Spin-resistant wire rope

### BOOM

6-section hydraulically telescoping boom of box construction  
(stages 2,3: synchronized; stages 4,5,6: synchronized)

### BOOM EXTENSION

2 double-acting hydraulic cylinders  
2 wire rope type telescoping devices

### JIB

Single stage folding type which stores alongside the boom

Triple offset (5°, 25°, 45°) type

### SINGLE TOP

Mounted and fixed on the top boom section.

### HOIST

Driven by hydraulic motor and via bevel gear reducer.  
With free-fall device.

Automatic brake (with foot brake for free-fall device)

2 single winches

With flow regulator valve with pressure compensation

### BOOM ELEVATION

1 double-acting hydraulic cylinder

### SWING

Hydraulic motor driven planetary gear reducer

Swing bearing

Negative brake

### OUTRIGGERS

Fully hydraulic X-type (floats mounted integrally)

Slides and jacks each provided with independent operation device.

Fully extended width 4.5m

Middle extended width 3.5m

Minimum extended width 2.5m

### OPERATION METHOD

Hydraulic pilot valve operation

### MAX. VERTICAL LOAD CAPACITY OF OUTRIGGER

11.2t ...TR-100ML

9.8t ...TR-100M

### POWER TAKE-OFF

PTO wet multi-plate clutch

### HYDRAULIC PUMPS

Gear pump

### HYDRAULIC OIL TANK CAPACITY

172 liters

### SAFETY DEVICES

Automatic moment limiter (AML)

Over-winding cutout device

Working area control device

Free-fall interlock device

Outrigger extension width detector

Level gauge

Hook safety latch

Hydraulic safety valve

Telescopic counterbalance valve

Elevation counterbalance valve

Jack pilot check valve

### EQUIPMENT

Air-conditioner with dehumidifier

Hydraulic oil temperature indication lamp

Radio

Oil cooler

Visual-type winch drum rotation indicator (option)

Operation pedals

ISO arrangement: for telescoping/auxiliary hoisting

TADANO arrangement: for elevating/telescoping

## CARRIER SPECIFICATIONS

### ENGINE

Model HINO W04D-TC  
Type 4-cycle, 4-cylinder, direct-injection, water-cooled diesel engine (with turbo charger)  
Piston displacement 4,009cc  
Max. output  
In operation: 77.2kW(105PS) at 2,000min<sup>-1</sup>(rpm)  
Underway: 110kW(150PS) at 3,000min<sup>-1</sup>(rpm)  
Max torque 373N-m(38.0kgf-m) at 1,800min<sup>-1</sup>(rpm)

### TORQUE CONVERTER

3-element, 1-stage unit (with automatic lock-up mechanism)

### TRANSMISSION

Power shift type (wet multi-plate clutch)  
3 forward and 1 reverse speeds (with Hi/Low settings)

### REDUCER

Single reduction type hypoid gear

### DRIVE

2-wheel drive (4X2) / 4-wheel drive (4X4) selection

### FRONT AXLE

Full floating type

### REAR AXLE

Full floating type

### SUSPENSION

Front Parallel leaf spring type  
Rear Parallel leaf spring type  
Spring lock device (option)

### STEERING

Fully hydraulic power steering  
With reverse steering correction mechanism

### BRAKE SYSTEM

Service Brake  
Hydro-pneumatic disk brake  
Parking Brake  
Mechanically operated, internal expanding duo-servo shoe type acting on drum at transmission case rear.  
Auxiliary Brake  
Electro-pneumatic operated exhaust brake  
Auxiliary braking device for operations

### FRAME

Welded box-shaped structure

### ELECTRIC SYSTEM

12 V DC. 2 batteries of 24V (100Ah)

### FUEL TANK CAPACITY

190 liters

### TIRES

Front 11R22.5-16PR  
Rear 11R22.5-16PR

### CAB

One-man type  
With interior equipment  
Rubber mounted type  
Fully adjustable foldable seat (with headrest and seat belt)  
Adjustable handle (tilt, telescoping)  
Intermittent type windshield/roof wiper (with washer)  
Power window  
Side visor

### SAFETY DEVICES

Rear wheel steering lock device  
Engine over-run alarm  
Overshift prevention device  
Parking brake alarm

### EQUIPMENT

Centralized oiling device

## GENERAL DATA

### DIMENSIONS

Overall length	7,290mm
Overall width	2,000mm
Overall height	2,800mm
Wheel base	2,750mm
Tread Front	1,680mm
Rear	1,680mm

### WEIGHTS

Gross vehicle weight	
Total	12,295kg
Front	6,200kg
Rear	6,095kg

### PERFORMANCE

Max. traveling speed	49km/h
Gradeability (tan $\theta$ )	0.6
Min. turning radius	3.9m (4-wheel steering) 6.9m (2-wheel steering)

**TOTAL RATED LOADS**

(1) With outriggers set  
 [BOOM]

Unit:ton

Outriggers fully extended (4.5m)							-360°-
A \ B	5.2m	8.8m	12.4m	16.0m	19.6m	23.2m	
1.0m	10.00(4.90)	4.90					
1.5m	10.00(4.90)	4.90	4.90				
2.0m	10.00(4.90)	4.90	4.90	4.00			
2.5m	10.00(4.90)	4.90	4.90	4.00	3.50		
3.0m	8.00(4.90)	4.90	4.90	4.00	3.50	2.00	
3.5m	6.10(4.90)	4.90	4.90	4.00	3.50	2.00	
4.0m	5.40(4.90)	4.90	4.90	4.00	3.50	2.00	
4.5m	(3.9m)	4.60	4.20	4.00	3.50	2.00	
5.0m		4.20	3.80	3.55	3.15	2.00	
5.5m		3.80	3.45	3.15	2.90	2.00	
6.0m		3.35	3.15	2.85	2.70	2.00	
7.0m		2.75	2.65	2.38	2.30	1.80	
8.0m		2.45(7.5m)	2.20	2.00	1.95	1.60	
9.0m			1.75	1.75	1.70	1.45	
10.0m			1.38	1.55	1.50	1.30	
11.0m			1.10	1.30	1.33	1.20	
12.0m				1.08	1.13	1.10	
13.0m				0.90	0.97	1.00	
14.0m				0.75	0.83	0.86	
15.0m				0.65(14.7m)	0.70	0.75	
16.0m					0.60	0.66	
17.0m					0.50	0.57	
18.0m					0.42	0.50	
19.0m					0.40(18.3m)	0.42	
20.0m						0.35	
21.9m						0.26	
a (°)	0 ~ 82						

A= Boom length B= Working radius  
 a= Boom angle range (for the unladen condition)

[BOOM]

Unit:ton

Outriggers middle extended (3.5m) -Over sides-						
A \ B	5.2m	8.8m	12.4m	16.0m	19.6m	23.2m
1.0m	10.00(4.90)	4.90				
1.5m	10.00(4.90)	4.90	4.90			
2.0m	10.00(4.90)	4.90	4.90	4.00		
2.5m	10.00(4.90)	4.90	4.90	4.00	3.50	
3.0m	8.00(4.90)	4.90	4.90	4.00	3.50	2.00
3.5m	6.10(4.90)	4.90	4.90	4.00	3.50	2.00
4.0m	5.40(4.90)	4.90	4.90	4.00	3.50	2.00
4.5m	(3.9m)	4.55	4.20	4.00	3.50	2.00
5.0m		3.75	3.65	3.40	3.15	2.00
5.5m		3.10	3.00	3.00	2.90	2.00
6.0m		2.60	2.55	2.60	2.70	2.00
7.0m		1.90	1.85	2.00	2.15	1.80
8.0m		1.60(7.5m)	1.35	1.55	1.70	1.60
9.0m			1.00	1.20	1.35	1.40
10.0m			0.75	0.95	1.08	1.13
11.0m			0.55	0.73	0.87	0.93
12.0m				0.56	0.70	0.76
13.0m				0.43	0.55	0.62
14.0m				0.33	0.43	0.51
15.0m				0.27(14.7m)	0.35	0.42
16.0m					0.25	0.33
17.0m					0.18	0.25
18.0m						0.19
a (°)	0 ~ 82				3 ~ 82	25 ~ 82

A= Boom length B= Working radius  
a= Boom angle range (for the unladen condition)





**PRECAUTIONS TO BE TAKEN WHEN THE OUTRIGGERS ARE EXTENDED:**

1. The values in parentheses are for TR-100M.
2. The total rated loads shown are for the case where the crane is set horizontally on firm level ground. They include the weights of the slings and hooks.  
 The values above the bold lines are based on the crane strength while those below are based on the crane stability.
3. Since the total rated loads are based on the actual working radii including the deflection of the boom, operations should be performed in accordance with the working radii.
4. Jib operations should be performed in accordance with the boom angle, irrespective of the boom length. The working radii are reference values for the case where the jib is mounted on a 23.2m boom.
5. The total rated load for the single top shall be the value obtained by subtracting the weight of the main hook from the total rated load of the boom and must not exceed 1.4t.
6. As a rule, free-fall operation should be performed only when lowering the hook alone. If a hoisted load must be lowered by free-fall operation, the load must be kept below 1/5th of the total rated load and sudden braking operations must be avoided.
7. The table below shows the standard number of part lines for each boom length. The load per line should not exceed 12.3kN(1.25tf) for the main winch and 13.7kN(1.4tf) for the auxiliary winch.

A	5.2m	8.8m	12.4m	16.0m	19.6m	23.2m	Single top
H	8(4)	4	4	4	4	4	1
K	10t Hook (4.9t Hook)						1.4t Hook
L	80kg (75kg)						20kg

The values in parentheses are for TR-100M.

A= Boom length H= No. of part-lines

K= Hook type L= Hook weight

8. The hoisting performance for the "Over sides" range will differ according to the extended width of the outriggers. Operations should be performed in accordance with the performance corresponding to the extended width. Also, although the hoisting performances for the "Over front" and "Over rear" ranges are equivalent to those of the "outriggers fully extended" condition, the front and rear ranges (angle a) will differ according to the width to which the outriggers are extended in the left and right directions.

Extended width	Middle extended (3.5m)	Minimum extended (2.5m)
Angle a°	25	15

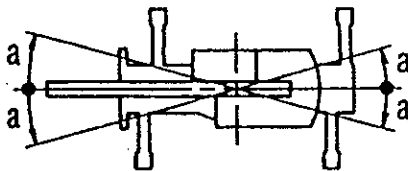

(2) Without outriggers

When the spring lock (option)  
is not available or not used:

Unit: ton

Travel with a load (1.6km/h or less) -Over front-		
A \ B	5.2m	8.8m
1.0m	1.00	0.50
3.5m	1.00	0.50
7.0m		0.50
a (°)	0 ~ 82	

When the spring lock (option) is used:

Unit: ton

B	Travel with a load (1.6km/h or less)					
	5.2m Boom		8.8m Boom		12.4m Boom	
	F	G	F	G	F	G
1.0m	3.20	1.70	3.20	1.70		
1.5m	3.20	1.70	3.20	1.70	3.20	1.70
2.0m	3.00	1.40	3.00	1.35	3.00	1.35
2.5m	2.60	0.95	2.55	0.90	2.55	0.90
3.0m	2.15	0.65	2.10	0.55	2.10	0.55
3.5m	1.80	0.40	1.75	0.30	1.75	0.30
4.0m			1.45	0.18	1.45	0.15
4.5m			1.20		1.20	
5.0m			1.00		1.00	
5.5m			0.85		0.85	
6.0m			0.70		0.70	
7.0m			0.40		0.45	
8.0m					0.25	
a (°)	0 ~ 82	0 ~ 82	0 ~ 82	53 ~ 82	39 ~ 82	68 ~ 82

A= Boom length B= Working radius F= Front G= 360°  
a= Boom angle range (for the unladen condition)

**PRECAUTIONS TO BE TAKEN WHEN THE OUTRIGGERS ARE NOT MOUNTED:**

1. The total rated loads shown are for the case where the tire air pressure on firm level ground is as specified (800kPa{8.00kgf/cm<sup>2</sup>}). They include the weights of the slings and hooks.  
 The total rated loads for using the spring lock are for the case where the spring-lock cylinder is extended as much as possible in addition to the above, which are based on the tire strength. The foundation, working conditions, etc. should be taken into consideration for actual work.
2. Since the total rated loads are based on the actual working radii including the deflection of the boom and the tires, operations should be performed in accordance with the working radii.
3. If the spring lock is not available or not used, no load can be hoisted in the over-side area. "Over front" crane operations should be performed only when the AML "over-front area indicator lamp" is lit. The boom must be kept inside a 2° area over front of the carrier when performing "Over front" crane operations without the outriggers.
4. The chart below shows the standard number of part-lines for each boom length.

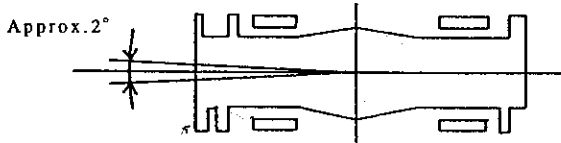

5. The total rated load for the single top shall be the value obtained by subtracting the weight of the main hook from the

A	5.2m~12.4m	Single top
H	4	1

A= Boom length H= No. of part-lines

total rated load of the boom and must not exceed 1.4t.

6. Free-fall operations should not be performed without outriggers.  
 Booms over 8.8m (12.4m when the spring lock is used) in length should not be used without outriggers.
7. The "Drive, Speed Selection" switch should be set to "4-wheel / Lo" for creeping while hoisting a load.
8. When creeping while hoisting a load, the swing brake should be applied, the load should be kept as close to the ground as possible but not touching the ground and the speed should be kept at 1.6km/h or less. In particular, any abrupt steering, starting or braking must be avoided.
9. Crane operations should not be performed when creeping while hoisting a load.

# WORKING RADIUS - LIFTING HEIGHT

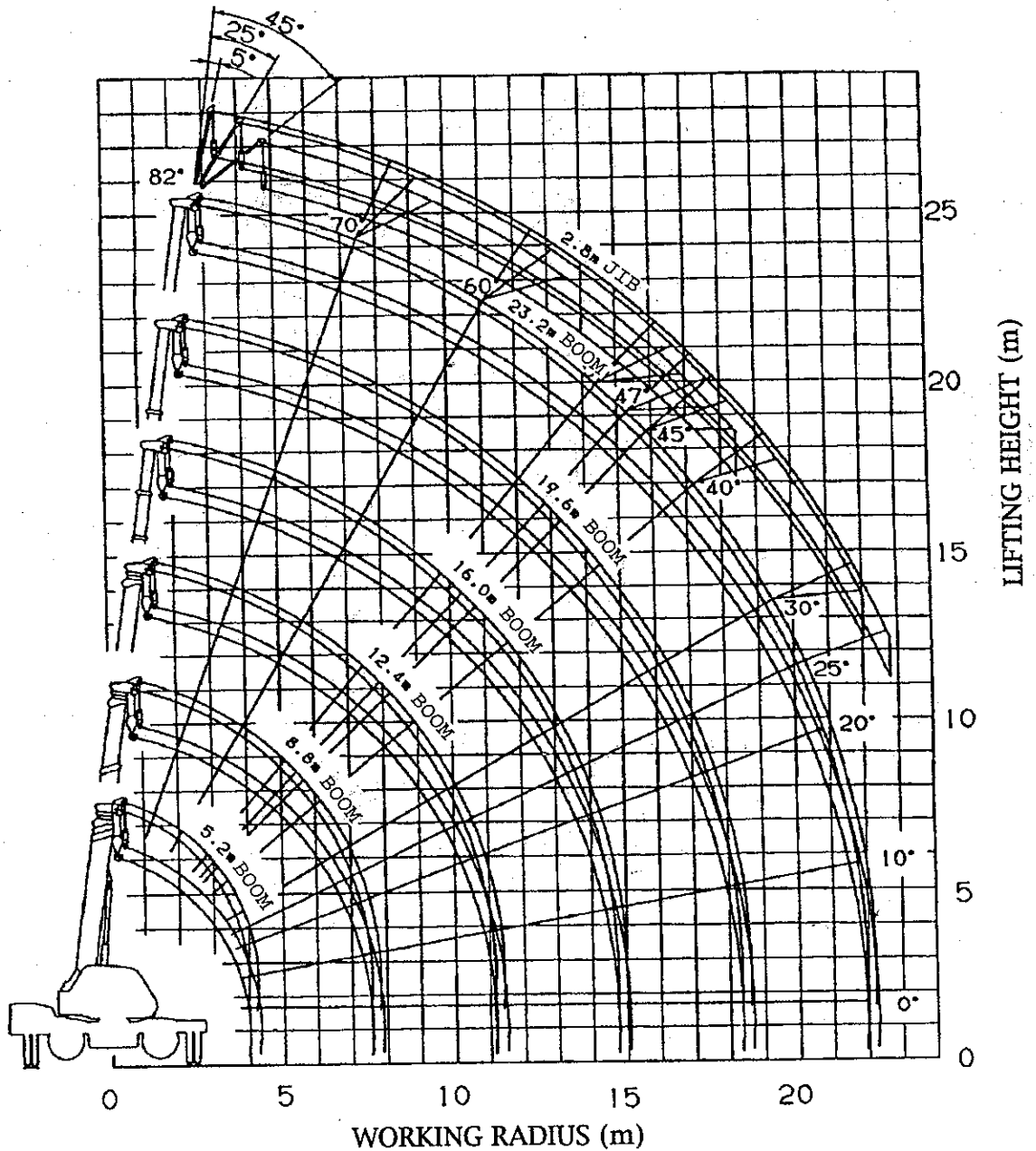

**NOTES:**

1. The deflection of the boom is not incorporated in the figure above.
2. The figure above is for the case where the outriggers are fully extended (360°).

**DIMENSIONS** (1/100)

